

Technical sheet :

MHT 10130



 **MANITOU**
HANDLING YOUR WORLD

Capacities		Metric
Max. capacity		13000 kg
Load center of gravity	c	600 mm
Max. lifting height		9.65 m
Maximum outreach		5.17 m
Weight and dimensions		
Overall length	l1	6.14 m
Unladen weight (with forks)		18490 kg
Ground clearance	m4	0.44 m
Wheelbase	y	3.37 m
Overall width	b1	2.51 m
Overall height	h17	2.99 m
Overall cab width	b4	0.93 m
Tilt-up angle	a4	18 °
Tilt-down angle	a5	117 °
External turning radius (over tyres)	Wa1	5.34 m
Outer turning radius (with forks)	b15	5.34 m
Forks length / width / section	l / e / s	70 mm x 1200 mm x 200 mm
Wheels		
Standard tires		Aeolus - A2237 - 17.5 R25
Number of front wheels / rear wheels		2 / 2
Steering wheels (front / rear)		2 / 2
Drive wheels (front / rear)		2 / 2
Steering mode		2 wheel steer, 4 wheel steer, Crab mode
Engine		
Engine brand		Mercedes
Engine nom		Stage IV, Tier 4 final
Engine model		OM 934 LA. E4-3
Number of cylinders / Capacity of cylinders		4 - 5100 cm³
Engine power (Hp / kW)		176 Hp / 129 kW
Max. torque / Engine rotation		750 Nm@1600 rpm
Engine cooling system		Water
Number of batteries		2
Battery voltage		12 V
Drawbar pull		10800 daN
Transmission		
Transmission type		Hydrostatic
Number of gears (forward / reverse)		2 / 2
Max. travel speed		31 km/h
Parking brake		Automatic Negative Hand-brake
Service brake		Oil-immersed multi-discs on front & rear axles
Gradeability (laden)		34 %
Hydraulics		
Hydraulic pump type		Variable pump
Hydraulic flow - Pressure		180 l/min - 300 bar
Tank capacities		
Engine oil		21 l
Hydraulic oil		290 l
Fuel		315 l
Diesel Exhaust fluid (AdBlue® type)		63 l
Noise and vibration		
Noise to environment (LWA)		107 dB
Vibration on hands/arms		2.50 m/s²
Miscellaneous		
Cab certification		Cabin ROPS - FOPS level 2
Controls		JSM
Attachment recognition system (E-Reco)		Standard

MHT 10130 - Dimensional drawing

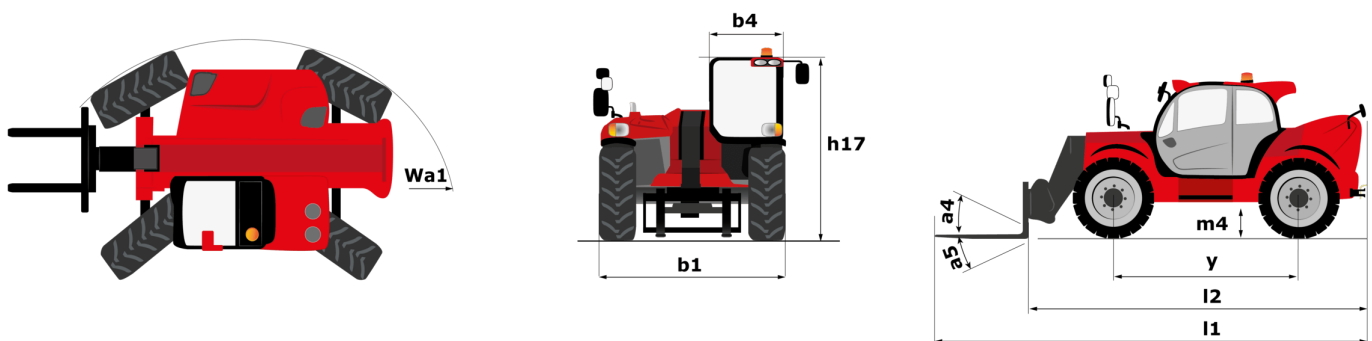



Head Office

B.P. 249 - 430 rue de l'Aubinière

44150 Ancenis Cedex - France

Tel: +33 (0)2 40 09 10 11 - Fax: +33 (0)2 40 09 10 97

www.manitou.com



This publication provides a description of the configuration versions and options for Manitou products, which may differ for equipment. The equipment presented in this brochure may be part of a series, as an option, or it may not be available, depending on the versions. Manitou reserves the right, at any time and without notice, to amend the specifications described and represented. The specifications provided do not bind the manufacturer. For more details, please contact your Manitou agent. This is not a contractually binding document. The presentation of the products is not contractually binding. List of specifications non-exhaustive. The logos as well as the visual identity of the company are owned by Manitou and cannot be used without authorisation. All rights reserved. The photos and diagrams contained in this brochure are only provided for consultation and information purposes.

MANITOU BF SA - Limited company with board of directors - Share capital: 39,668,399 euros - 857 802 508 RCS Nantes